



This drawing includes confidential information which is the property of ASHCROFT INC. This copy is loaned for a specific purpose, with the understanding that it will not be reproduced or used for any other purpose or disclosed to others, and it will be returned on demand.

**ASHCROFT** INC.

250 EAST MAIN STREET  
STRATFORD, CT 06614

NOTE 1: PANEL CUTOUT-  $\varnothing 4.94$  [125] +/- 1/32 [1]

NOTE 2: PANEL THICKNESS- 1/16 [2] TO 1/4 [6]

NOTE 3: BRACKET POSITIONED FOR 1/4" PANEL

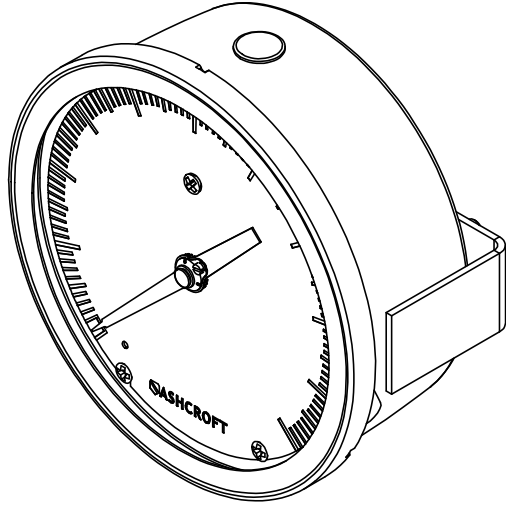
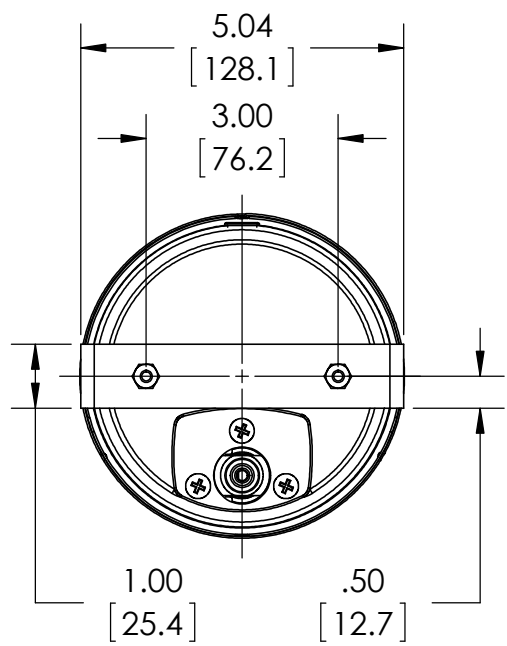
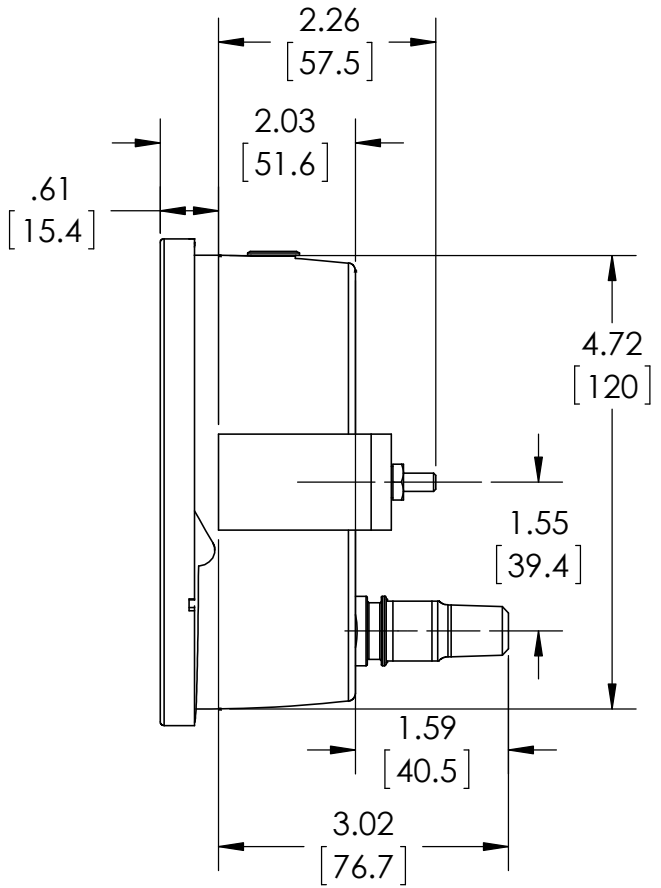
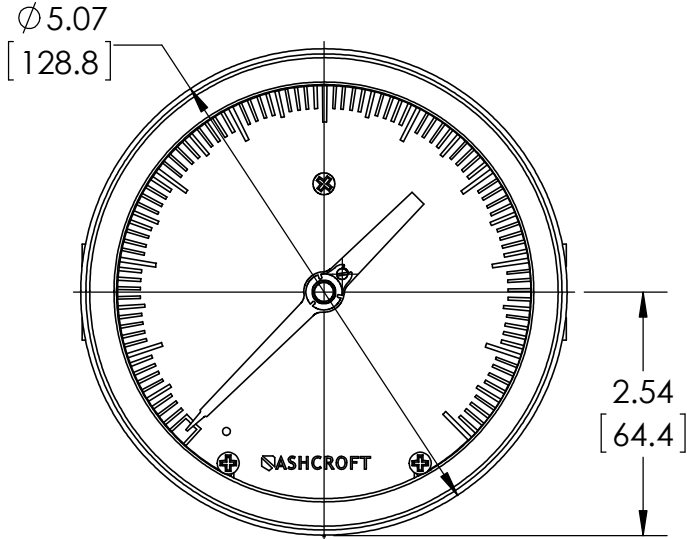

DIMENSIONS IN [ ] ARE MILLIMETERS

REV.	ECO	DESCRIPTION	BY	DATE
A	0004508	RELEASED GENERAL DIMS.	MJS	6/20/2011

This print certified correct for		<b>General Dimensions</b>			
Customer's Name		45 1009 02B XUC SERIES			
Customer's Order No.	Drawn MJS	Date 6/20/11	Date of Issue		
Ashcroft Order No.	Checked	Date	SHEET-1		Rev.
Certified by	Date	Approved	Date	<b>70A3500</b>	<b>A</b>