

Low pressure differential transducer model CXLdp

Accuracy 0,4 % and 0,8 % F.S.

Features

- Rugged ABS package capable of DIN rail or standard panel mounting
- LED power status indicator to assist in trouble shooting or quickly locating the instrument in a duct
- Detachable DIN style terminal block reduces wiring errors and field wiring time
- 25 standard pressure ranges all capable of withstanding 1 bar without damage or calibration change
- Digitally compensated, 0,4 % F.S. and 0,8 % F.S. accuracy models
- NIST traceable



Ranges

0 ... 25 Pa up to 0 ... 6 kPa dp
 $\pm 0/25$ Pa up to $\pm 0/5$ kPa dp

Applications

Low pressure measurement for building energy management and comfort control
 Flow measurement
 Filter monitoring

Featuring a highly reliable variable capacitance sensor using the patented Ashcroft® SiGlas™ sensor. This ultra thin single crystal diaphragm provides inherent sensor repeatability and stability.

Sensor cross section

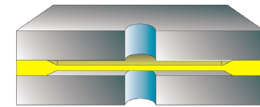

The silicon diaphragm sensor has no glues or other organics to contribute a drift or mechanical degradation over time.

| Technical specification | CXLdp | | | | | | | | | | | | | | | | | | | | | | | | | | | | | | | | | | | | | | | | | | | | | | | | | | | | |
|---|---|----------------------|------------|-----------|-----------|-----------|-----------|------------|------------|------------|------------|------------|------|------|-------------|-----|------|-----|------|---|-----|---|-----|---|---|----|----|---------------------|----------|----------|-----------|-----------|-----------|-----------|-----------|------------|------------|------------|------------|------------|-------------|------------|-----------|------------|-----------|---------|---------|-----------|---------|---------|----------|--|--|
| Measuring principle | Differential Si-glass/aluminum capacitor with single crystal silicon diaphragm | | | | | | | | | | | | | | | | | | | | | | | | | | | | | | | | | | | | | | | | | | | | | | | | | | | | |
| Ranges | <table border="1"> <tr> <td>unidirectional in Pa</td> <td>25</td> <td>60</td> <td>100</td> <td>160</td> <td>250</td> <td>400</td> <td>600</td> <td>1000</td> <td>1600</td> <td>2500</td> <td>4000</td> <td>6000</td> </tr> <tr> <td>in in. W.C.</td> <td>0,1</td> <td>0,25</td> <td>0,5</td> <td>0,75</td> <td>1</td> <td>1,5</td> <td>2</td> <td>2,5</td> <td>3</td> <td>5</td> <td>10</td> <td>15</td> </tr> <tr> <td>bidirectional in Pa</td> <td>± 25</td> <td>± 60</td> <td>± 100</td> <td>± 160</td> <td>± 250</td> <td>± 400</td> <td>± 600</td> <td>± 1000</td> <td>± 1600</td> <td>± 2500</td> <td>± 4000</td> <td>± 5000</td> </tr> <tr> <td>in in. W.C.</td> <td>$\pm 0,05$</td> <td>$\pm 0,1$</td> <td>$\pm 0,25$</td> <td>$\pm 0,5$</td> <td>± 1</td> <td>± 2</td> <td>$\pm 2,5$</td> <td>± 3</td> <td>± 5</td> <td>± 10</td> <td></td> <td></td> </tr> </table> | unidirectional in Pa | 25 | 60 | 100 | 160 | 250 | 400 | 600 | 1000 | 1600 | 2500 | 4000 | 6000 | in in. W.C. | 0,1 | 0,25 | 0,5 | 0,75 | 1 | 1,5 | 2 | 2,5 | 3 | 5 | 10 | 15 | bidirectional in Pa | ± 25 | ± 60 | ± 100 | ± 160 | ± 250 | ± 400 | ± 600 | ± 1000 | ± 1600 | ± 2500 | ± 4000 | ± 5000 | in in. W.C. | $\pm 0,05$ | $\pm 0,1$ | $\pm 0,25$ | $\pm 0,5$ | ± 1 | ± 2 | $\pm 2,5$ | ± 3 | ± 5 | ± 10 | | |
| unidirectional in Pa | 25 | 60 | 100 | 160 | 250 | 400 | 600 | 1000 | 1600 | 2500 | 4000 | 6000 | | | | | | | | | | | | | | | | | | | | | | | | | | | | | | | | | | | | | | | | | |
| in in. W.C. | 0,1 | 0,25 | 0,5 | 0,75 | 1 | 1,5 | 2 | 2,5 | 3 | 5 | 10 | 15 | | | | | | | | | | | | | | | | | | | | | | | | | | | | | | | | | | | | | | | | | |
| bidirectional in Pa | ± 25 | ± 60 | ± 100 | ± 160 | ± 250 | ± 400 | ± 600 | ± 1000 | ± 1600 | ± 2500 | ± 4000 | ± 5000 | | | | | | | | | | | | | | | | | | | | | | | | | | | | | | | | | | | | | | | | | |
| in in. W.C. | $\pm 0,05$ | $\pm 0,1$ | $\pm 0,25$ | $\pm 0,5$ | ± 1 | ± 2 | $\pm 2,5$ | ± 3 | ± 5 | ± 10 | | | | | | | | | | | | | | | | | | | | | | | | | | | | | | | | | | | | | | | | | | | |
| Overpressure | | | | | | | | | | | | | | | | | | | | | | | | | | | | | | | | | | | | | | | | | | | | | | | | | | | | | |
| Proof pressure in bar | 1,0 | | | | | | | | | | | | | | | | | | | | | | | | | | | | | | | | | | | | | | | | | | | | | | | | | | | | |
| Burst pressure in bar | 1,7 | | | | | | | | | | | | | | | | | | | | | | | | | | | | | | | | | | | | | | | | | | | | | | | | | | | | |
| Static pressure in bar | 1,7 | | | | | | | | | | | | | | | | | | | | | | | | | | | | | | | | | | | | | | | | | | | | | | | | | | | | |
| Pressure type | Differential, gauge, vacuum and compound | | | | | | | | | | | | | | | | | | | | | | | | | | | | | | | | | | | | | | | | | | | | | | | | | | | | |
| Process connection | 1/4" barbed fittings, 1/8 NPT female, according to ANSI/ASME B1.20.1 | | | | | | | | | | | | | | | | | | | | | | | | | | | | | | | | | | | | | | | | | | | | | | | | | | | | |
| Medium | Clean and dry air, non conducting and non corrosive gases | | | | | | | | | | | | | | | | | | | | | | | | | | | | | | | | | | | | | | | | | | | | | | | | | | | | |
| Material | | | | | | | | | | | | | | | | | | | | | | | | | | | | | | | | | | | | | | | | | | | | | | | | | | | | | |
| Process connection | Brass | | | | | | | | | | | | | | | | | | | | | | | | | | | | | | | | | | | | | | | | | | | | | | | | | | | | |
| Sensor element | Silicon, aluminum, glass | | | | | | | | | | | | | | | | | | | | | | | | | | | | | | | | | | | | | | | | | | | | | | | | | | | | |
| Case | NEMA type 1 fire-retardant ABS (meets UL 94-5VA) | | | | | | | | | | | | | | | | | | | | | | | | | | | | | | | | | | | | | | | | | | | | | | | | | | | | |
| Power supply | 12 ... 36 VDC for output signal 4-20 mA, 14 ... 36 VDC or 24 VAC (± 20 %) for VDC output, reverse polarity protected | | | | | | | | | | | | | | | | | | | | | | | | | | | | | | | | | | | | | | | | | | | | | | | | | | | | |
| Output signal | 4-20 mA (2-wire), 0-10 VDC (3-wire) with user selectable 0-5 VDC option | | | | | | | | | | | | | | | | | | | | | | | | | | | | | | | | | | | | | | | | | | | | | | | | | | | | |
| Max loop resistance for 4-20 mA | $\leq (U_B - 12 V) / 0,022 A$ | | | | | | | | | | | | | | | | | | | | | | | | | | | | | | | | | | | | | | | | | | | | | | | | | | | | |
| Supply current | Max. 20 mA for 4-20 mA output signal | | | | | | | | | | | | | | | | | | | | | | | | | | | | | | | | | | | | | | | | | | | | | | | | | | | | |
| Optical process diagnostics | LED visual indicator | | | | | | | | | | | | | | | | | | | | | | | | | | | | | | | | | | | | | | | | | | | | | | | | | | | | |
| Accuracy according to DIN 16 086 | 0,4 % or 0,8 % F.S. (terminal point, includes the effects of linearity, hysteresis and repeatability) | | | | | | | | | | | | | | | | | | | | | | | | | | | | | | | | | | | | | | | | | | | | | | | | | | | | |
| Long term stability | $\leq 0,5$ % F.S. / year | | | | | | | | | | | | | | | | | | | | | | | | | | | | | | | | | | | | | | | | | | | | | | | | | | | | |
| Response time (10 ... 90 %) | 250 ms | | | | | | | | | | | | | | | | | | | | | | | | | | | | | | | | | | | | | | | | | | | | | | | | | | | | |
| Warm-up time | 15 sec | | | | | | | | | | | | | | | | | | | | | | | | | | | | | | | | | | | | | | | | | | | | | | | | | | | | |
| Permissible | | | | | | | | | | | | | | | | | | | | | | | | | | | | | | | | | | | | | | | | | | | | | | | | | | | | | |
| Operation temperature | -18 ... 70 °C | | | | | | | | | | | | | | | | | | | | | | | | | | | | | | | | | | | | | | | | | | | | | | | | | | | | |
| Storage temperature | -40 ... 82 °C | | | | | | | | | | | | | | | | | | | | | | | | | | | | | | | | | | | | | | | | | | | | | | | | | | | | |
| Compensated temperature range | 2 ... 54 °C | | | | | | | | | | | | | | | | | | | | | | | | | | | | | | | | | | | | | | | | | | | | | | | | | | | | |
| Temperature influence | $\pm 0,54$ % / 10 K (ref. 20 °C) | | | | | | | | | | | | | | | | | | | | | | | | | | | | | | | | | | | | | | | | | | | | | | | | | | | | |
| Mounting position error (zero adjustable) | ≤ 1 % / g (calibration in vertical position is standard) | | | | | | | | | | | | | | | | | | | | | | | | | | | | | | | | | | | | | | | | | | | | | | | | | | | | |
| Adjustments | Zero ± 5 % F.S., Span ± 5 % F.S., externally accessible | | | | | | | | | | | | | | | | | | | | | | | | | | | | | | | | | | | | | | | | | | | | | | | | | | | | |
| CE-mark/EMC | Compliant to EN 61326 (1997) + A1 (1998) + A2 (2001) Annex A | | | | | | | | | | | | | | | | | | | | | | | | | | | | | | | | | | | | | | | | | | | | | | | | | | | | |
| Electrical connection | Euro style pluggable terminal block accepts 12-26 gauge wire (0,128 bis 3,31 mm ²), optional 1/2" conduit/plenum mounting bracket, suitable for cable gland M20x1,5 | | | | | | | | | | | | | | | | | | | | | | | | | | | | | | | | | | | | | | | | | | | | | | | | | | | | |
| Mounting | Threaded fastener for wall mounting or DIN rail types EN 50022, EN 50035 and 50045 | | | | | | | | | | | | | | | | | | | | | | | | | | | | | | | | | | | | | | | | | | | | | | | | | | | | |
| Protection according EN 60 529/IEC 529 | IP40, IP54 assembled with 1/2" conduit/plenum mounting bracket and cover kit | | | | | | | | | | | | | | | | | | | | | | | | | | | | | | | | | | | | | | | | | | | | | | | | | | | | |
| Weight in kg | 0,07; complete with 1/2" conduit/plenum mounting bracket and cover kit 0,15 | | | | | | | | | | | | | | | | | | | | | | | | | | | | | | | | | | | | | | | | | | | | | | | | | | | | |

All specifications are subject to change without notice.

General dimensions in mm

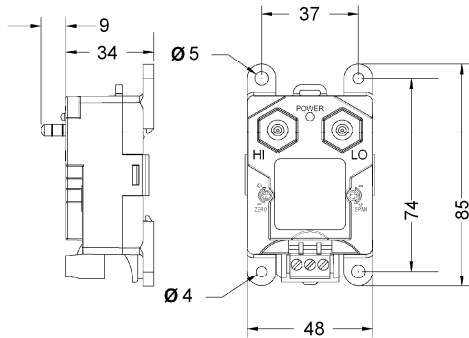

MB2 1/4" barbed fittings

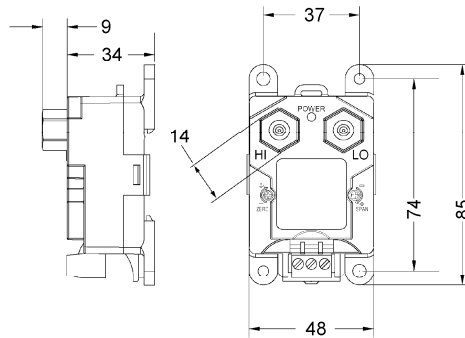

F01 1/8 NPT female fittings

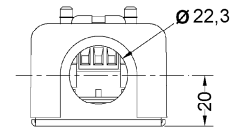
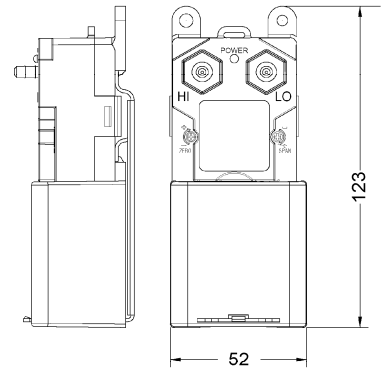

Assembled with 1/2" conduit/plenum kit



Standard DIN rail mount

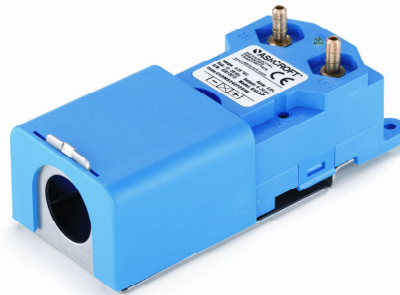

Optional 1/2" plenum/conduit kit

Load Limitations 4-20mA Output

Loop Resistance (Ω)

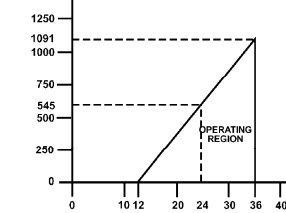

LOOP SUPPLY VOLTAGE (VDC)
 $V_{min} = 12V + [0.022A \cdot (R_L)]$
 *includes a 10% safety factor
 $R_L = R_S + R_W$
 R_L = Loop Resistance (ohms)
 R_S = Sense Resistance (ohms)
 R_W = Wire Resistance (ohms)

Rev. A

Order information

| Type | Accuracy | Process connection | Output signal | Ranges | | Options |
|---------------|-----------|------------------------|-----------------------------|--|--|--|
| | | | | in. W.C. | Pa and kPa | |
| (CX) CXLdp | (4) 0,4 % | (MB2) 1/4" barbed male | (42) 4-20 mA | Unidirectional | Unidirectional | (NH) Tagging wired |
| | (8) 0,8 % | (F01) 1/8 NPT female | (10) 0-10 VDC ¹⁾ | (P1IW) 0/ 0,1 (P25IW) 0/ 0,25 (P5IW) 0/ 0,5 (P75IW) 0/ 0,75 (1IW) 0/ 1,0 (2IW) 0/ 2,0 (2P5IW) 0/ 2,5 (3IW) 0/ 3 (5IW) 0/ 5 (10IW) 0/ 10 (25IW) 0/ 25 | (25PA) 0/ 25 Pa (60PA) 0/ 60 Pa (100PA) 0/ 100 Pa (160PA) 0/ 160 Pa (250PA) 0/ 250 Pa (400PA) 0/ 400 Pa (600PA) 0/ 600 Pa (1KPA) 0/ 1 kPa (1P6KPA) 0/ 1,6 kPa (2P5KPA) 0/ 2,5 kPa (4KPA) 0/ 4 kPa (6KPA) 0/ 6 kPa | (AH) 1/2" conduit/plenum mounting bracket and cover kit (delivered with transducer) |
| | | | | Bidirectional | Bidirectional | (101A213-01) 1/2" conduit/plenum mounting bracket and cover kit (separately ordered) |
| | | | | (P1IWL) ±0,1 (P25IWL) ±0,25 (P5IWL) ±0,5 (1IWL) ±1 (2IWL) ±2 (5IWL) ±5 (10IWL) ±10 (15IWL) ±15 | (25PAL) ±25 Pa (60PAL) ±60 Pa (100PAL) ±100 Pa (160PAL) ±160 Pa (250PAL) ±250 Pa (400PAL) ±400 Pa (600PAL) ±600 Pa (1KPAL) ±1 kPa (1P6KPAL) ±1,6 kPa (2P5KPAL) ±2,5 kPa (4KPAL) ±4,0 kPa (5KPAL) ±5,0 kPa | (CD4S) 3-point calibration certificate |
| | | | | | | (RH) 9-point calibration certificate, traceable to a national standard |

1) includes user selectable option 0-5 VDC output

Order example

| Type | Accuracy | Process connection | Output signal | Range | Options |
|------|----------|--------------------|---------------|-------|---------|
| CX | 8 | MB2 | 42 | 100PA | AH |

Ashcroft Instruments GmbH

Germany
 Max-Planck-Str. 1, D-52499 Baesweiler
 P.O. Box 11 20, D-52490 Baesweiler
 Tel.: +49 (0) 2401 808-0, Fax: +49 (0) 2401 808-125

France
 „206" ZA du Mandinet, 1/3 Rue des Campanules
 F-77185 Lognes
 Tel.: +33 (0) 1 60 37 25 30, Fax: +33 (0) 1 60 37 25 39

Website: www.ashcroft.eu

United Kingdom
 Unit 5 William James House
 Cowley Road, Cambridge CB4 0WX
 Tel.: +44 (0) 12 23 39 55 00, Fax: +44 (0) 12 23 39 55 01

e-Mail: sales@ashcroft.com