

Type 1005P, XUL Fire Protection Sprinkler Service Gauge



FEATURES

- Underwriters Laboratory listed and Factory Mutual approved
- Corrosion-resistant ABS case
- Heat-resistant polycarbonate push-in window
- Patented PowerFlex™ movement with polyester segment
- True Zero™ indication, a unique safety feature

Ashcroft® fire protection sprinkler gauges are Underwriters Laboratory listed and Factory Mutual approved for fire protection sprinkler service. The case material on Type 1005P, XUL gauges is ABS. The 0-300 psi pressure range is used on “wet” systems where water is available to the sprinkler heads. The 0-80 retard to 250 psi pressure range is used on dry systems where the lines are filled with air pressure until system activation.

The patented PowerFlex™ movement with polyester segment is designed to provide unequalled shock and vibration resistance resulting in superior performance and extended gauge life.

True Zero™ indication, a standard feature on these gauges, reduces the potential risk of installing a damaged gauge on your equipment.

PRODUCT SPECIFICATIONS

- Ashcroft® Model No.:** 1005P, XUL
- Accuracy:** ASME B 40.100
Grade B (±3-2-3% of span)
- Size:** 3 1/2”
- Case:** ABS (Polycarbonate blend) 1/2
- Ring:** None
- Window:** Polycarbonate, push-in
- Dial:** Black figures on white background
- Pointer:** Black, aluminum
- Bourdon tube:** “C” shaped bronze
- Movement:** Patented PowerFlex™ with polyester segment
- Socket:** Brass
- Restrictor:** None
- Connection:** 1/4 NPT lower
- Ranges:** 0-300 psi (water)
0-80 retard to 250 psi (air)

Operating

temperature: -40°F to 150°F; -40°C to 65°C

UL 393 Listed, UL of Canada Listed and FM approved. Equivalent (single or dual scale) metric scales are available

OPTIONAL FEATURES

- Customized dials
- Other UL listed ranges on application
- FlutterGuard™

HOW TO ORDER (Typical example)

35 W 1005 P H 02L XUL 300#

Dial Size: 3 1/2” _____

Movement: Patented PowerFlex™ _____

Case Type Number: 1005P _____

Case Material: ABS _____

Socket Material: Brass _____

Connection Size/Location: 1/4 NPT Lower _____

Listing: UL listed, FM approved _____

Range: 0/300 psi _____

Type 1005P, XUL Fire Protection Sprinkler Service Gauge

DIMENSIONS

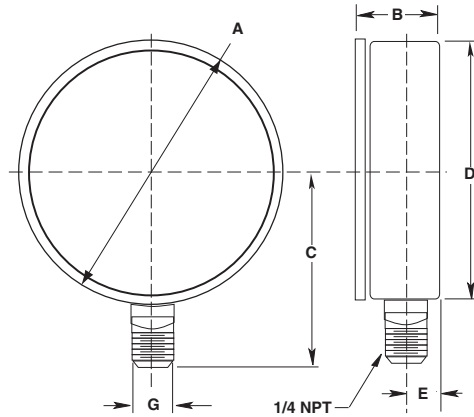

SIZE/TYPE	A	B	C	D	E	G
3 1/2"	3.70	1.14	2.72	3.61	0.47	0.56
1005P, XUL	(94)	(29)	(69)	(92)	(11.9)	(14.2)